

THERMOJET® H 2000 SERIES

The Ultimate Way To Dehydrate Oils Used In The Hydrocarbon Processing Industry



Available as Cart Mounted and Trailer Mounted Units

FEATURES

- Simplicity = Reliability & Maintainability
- Choice of Steam or Electric Heater
- Proprietary Dual-Stage Jet Mixer
- Corrosion-Resistant Stainless Steel Construction
- Particulate Filtration to ISO 13/10
- 2 Close-Coupled Gear Pumps Driven by Single Motor
- Streamlined Instrumentation with Panel Mounted Gauges
- Enclosed Cabinet Design with Hinged Door for Easy Access
- CSA Listed for Class I Division 2 Groups B/C/D T4
- Available in Various International Voltages
- Oil Vapor Discharge Well within OSHA Standards (2.3 mgs/m³ vs. 5 mgs/m³)
- 0-8 PPM Oil Discharge in Condensate, Far Surpassing EPA Regulations of 15 PPM For "Clean" Sewers
- Process Flow Rate 180 GPH (680 lph)

LEGEND

1. 12KW Oil Heater
2. Filter
3. Dual-Stage Jet Mixer
4. Separation Tank
5. Level Controller
6. Oil Pumps & Motor
7. Oil In/Out & Sight Glass
8. Condensate Purifier Assembly
9. Condensate Trap
10. Oil Mist Eliminator/Vapor Exhaust

BENEFITS

- Removes All Three Forms of Water
- No Waste Oil Disposal
- Improved Machinery Reliability
- No Machinery Failures Due To Poor Quality Oil
- No Oily Discharge
- No Emissions Penalties From Environmental Agencies
- Greatly Reduces New Oil Purchases



THERMOJET® H 2000 SERIES

The Ultimate Way To Dehydrate Oils Used In The Hydrocarbon Processing Industry

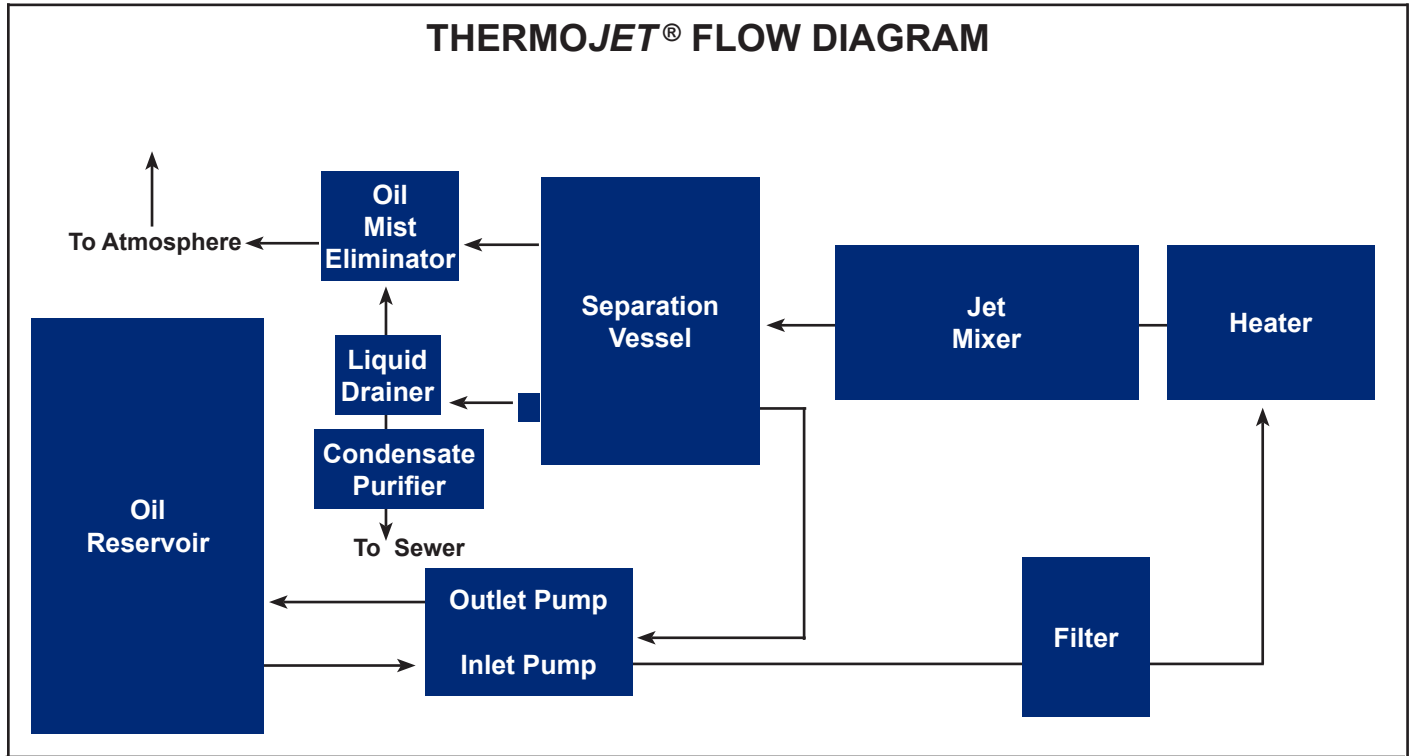

How The THERMOJET® Oil Purifier Functions

Oil is drawn from a reservoir by a pump through a sight flow indicator and a Y-strainer. A filter removes small quantities of dirt, wear particles and corrosion products. The oil temperature is elevated by a heater. Downstream of the heater, atmospheric air is filtered as it is drawn into the wet oil by a highly efficient, proprietary Jet Mixer. As the air contacts and mixes with the oil, the liquid water changes into a vapor. A supply of compressed air is not required. Dehydrated oil collects in a level-controlled separation tank. In the space above the oil level, the water vapor separates from the oil. The unique design of the THERMOJET® separation tank prevents any condensate from recontaminating the oil. Clean, dry oil is drawn from the tank by a second gear pump which delivers it back to the machinery reservoir or oil tank. The clean water vapor which passes through an oil mist coalescer exhausts to atmosphere. The water condensate passes from a liquid trap into a Condensate Purifier Assembly which removes 100% of the coalesced oil before it is discharged into a clean sewer.

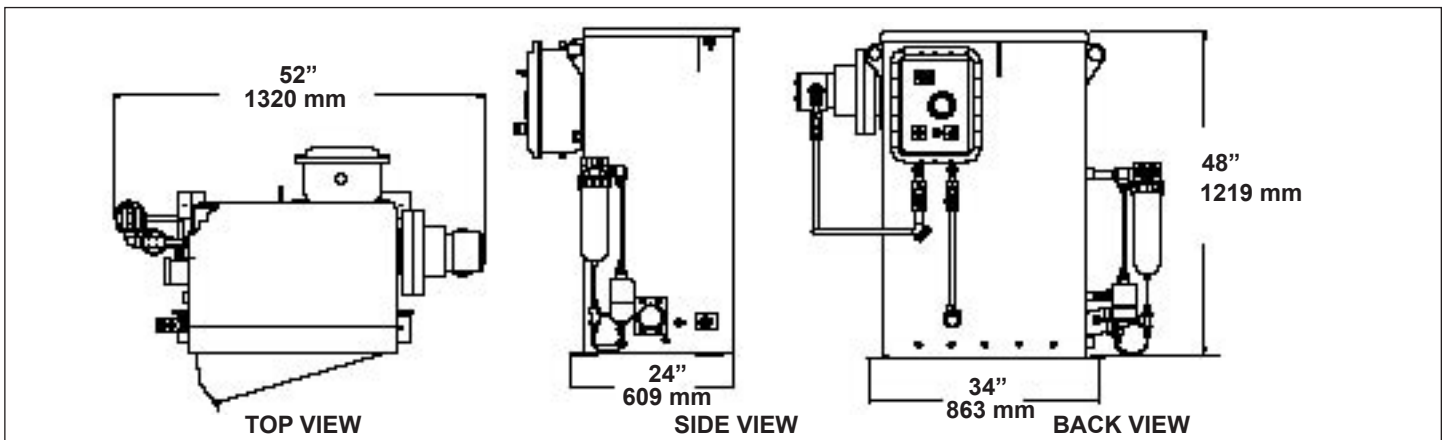

FOR SALES, 24 HOUR SERVICE OR TECHNICAL INFORMATION:

1740 Stebbins, Houston, Texas 77043

713.464.6266 • FAX 713.464.9871 • 800.800.LUBE

[Click here to contact us at LSC • www.lsc.com](http://www.lsc.com)